



Junior Maths Mastery Challenge Sample

Paper D

Section A

Questions 1 to 5 carry 3 marks each.

1. A number is written below. Its digits follow a pattern.

25719257192571925719...

Find the sum of its first 52 digits.

[Patterns and sequences]

The repeating block of digits is 2 5 7 1 9.

There are 5 digits in the block.

$$2 + 5 + 7 + 1 + 9 = 24$$

The sum of the digits in the block is 24.

$$52 \div 5 = 10 \text{ R } 2$$

There are 10 such blocks and the next 2 digits are 2 and 5.

$$10 \times 24 = 240$$

$$240 + 2 + 5 = 247$$

The sum of its first 52 digits is 247.

(A) 242

(B) 247

(C) 254

(D) 255

(E) 264

2. 12, 47, 79 are examples of 2-digit numbers with digits in ascending order. How many such 2-digit numbers are there?

[Combinatorics]

If the digit in the tens place is 1, the digit in the ones place can be 2 to 9.

There are 8 such 2-digit numbers.

If the digit in the tens place is 2, the digit in the ones place can be 3 to 9.

There are 7 such 2-digit numbers.

If the digit in the tens place is 3, the digit in the ones place can be 4 to 9.

There are 6 such 2-digit numbers.

If we continue this pattern, we will get the following:

$$8 + 7 + 6 + 5 + 4 + 3 + 2 + 1 = 36$$

There are 36 such 2-digit numbers.

(A) 32

(B) 34

(C) 36

(D) 45

(E) 55

3. How many triangles are there in the figure?

[Spatial visualisation]

The figure is 1 large triangle.
The figure itself is made up of 8 small triangles.

Count the triangles made up of two small triangles.
There are 6 such triangles.

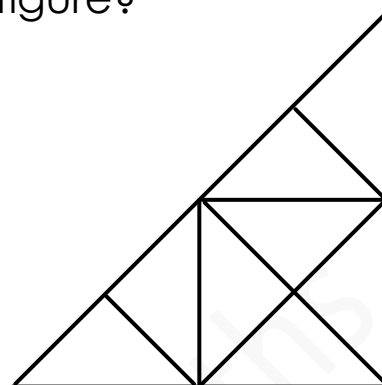
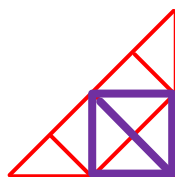
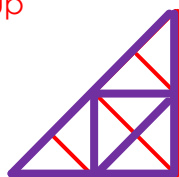

Count the triangles made up of four small triangles.
There are 2 such triangles.



$1 + 8 + 6 + 2 = 17$
There are 17 triangles in the figure.

(A) 15

(B) 16

(C) 17

(D) 18

(E) None of the above



4. Boxes A, B, C, D and E contain 370 marbles altogether.
Boxes A and B contain 160 marbles altogether.
Boxes B and C contain 148 marbles altogether.
Boxes C and D contain 140 marbles altogether.
Boxes D and E contain 128 marbles altogether.
How many marbles do boxes B and D contain altogether?

[Problem solving]

Boxes A and B contain 160 marbles altogether.

$$370 - 160 = 210$$

Boxes C, D and E contain 210 marbles altogether.

$$210 - 128 = 82$$

Box C contains 82 marbles.

$$140 - 82 = 58$$

Box D contains 58 marbles.

$$148 - 82 = 66$$

Box B contains 66 marbles.

$$66 + 58 = 124$$

Boxes B and D contain 124 marbles altogether.

(A) 124

(B) 136

(C) 152

(D) 176

(E) None of the above

5. The figure is made up of three squares. The area of the shaded square is 25 cm^2 . Find the area of the figure.

[Mensuration / Simplify the problem]

Observe that from the dotted lines drawn as shown, the area of the medium square is 2 times the area of the small square. The area of the large square is 2 times the area of the medium square.

$$2 \times 25 = 50$$

The area of the medium square is 50 cm^2 .

$$2 \times 50 = 100$$

The area of the figure is 100 cm^2 .

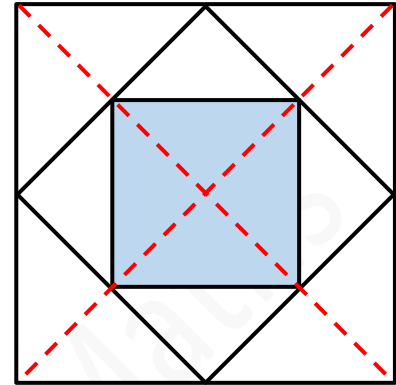

- (A) 75 cm^2 (B) 100 cm^2 (C) 125 cm^2
(D) 150 cm^2 (E) None of the above

Questions 6 to 10 carry 4 marks each.

6. The lines on the diagram show the paths from Point X to Point Y. Lisa wants to walk from Point X to Point Y. How many ways can she walk from Point X to Point Y, passing through points A and B?

(During each journey, she is not allowed to walk to a point more than once.)

[Combinatorics]

Find the paths from Point X to Point A.
There are 3 different paths.

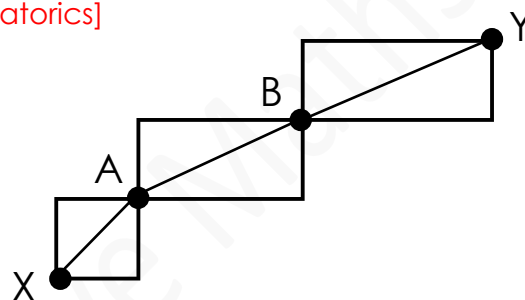
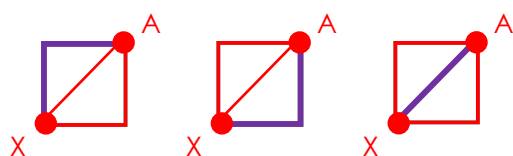

Observe that from Point A to Point B and from Point B to Point Y, there are 3 different paths as well.

$$3 \times 3 \times 3 = 27$$

She can walk from Point X to Point Y in 27 different ways.

(A) 9

(B) 12

(C) 15

(D) 27

(E) None of the above

7. Four of the five cubes below belong to the same cube. Which of them does not belong to the cube?

[Spatial visualisation]

(A)

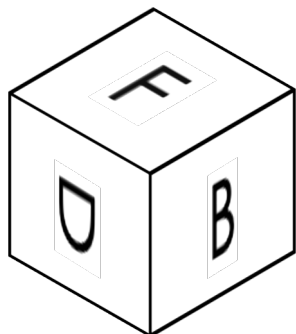

(B)

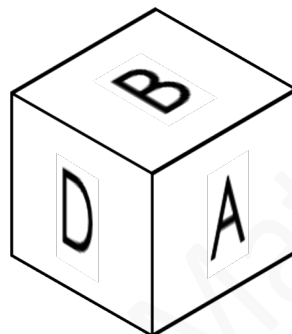

(C)

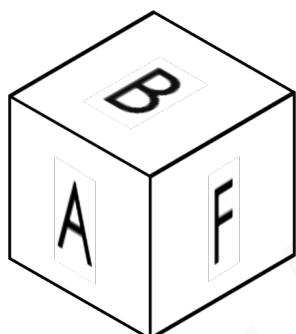

(D)

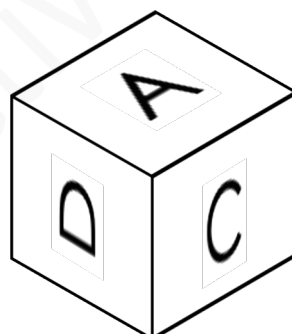

(E)

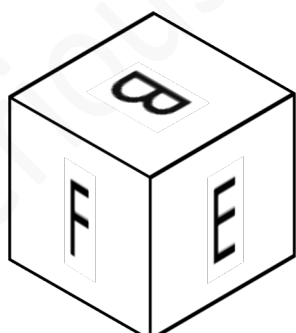

Observe that the cubes in (A) and (C) cannot belong to the same cube, so one of them must be incorrect.

If (A) belongs to the cube, then (B), (D) and (E) must also belong to the cube. But (E) is not possible.

(E) is only possible if (C) also belongs to the cube. So, (A) does not belong to the cube.

8. What is the ones digit in the following product?

$$\underbrace{2 \times 2 \times 2 \times \dots \times 2 \times 2 \times 2}_{30 \text{ digits } 2}$$

[Arithmetic]

2, 4, 8, 16, 32, 64, 128, 256, 512, ...

Observe that the digit in the ones place follows the pattern, 2, 4, 8, 6, 2, 4, 8, 6, 2,
The repeating block is '2 4 8 6'. There are 4 digits in the block.

$$30 \div 4 = 7 \text{ R } 2$$

There are 7 such blocks and the next 2 digits are 2 and 4.

The ones digit in the product is 4.

(A) 2

(B) 4

(C) 6

(D) 8

(E) None of the above

9. Joe and Paul are playing a game using 100 beads.
Each of them takes turn to remove 1 to 5 beads.
The player who removes the last bead loses the game.

Joe started the game. He removed a certain number of beads and claimed that he would definitely win the game now. How many beads did he remove? [Number Theory]

Joe started the game. After removing these beads, his turn would be after Paul.

Observe that regardless of the number of beads Paul removed in his turn, Joe could ensure that 6 beads were always removed when each of them took 1 turn.

If Paul removed 1 bead, Joe could remove 5 beads.

If Paul removed 2 beads, Joe could remove 4 beads.

If Paul removed 3 beads, Joe could remove 3 beads, and so on.

Also observe that if 7 beads were left on Paul's turn, Joe would definitely win:

a) Paul removed 1 bead, Joe removed 5 beads and Paul had to remove the last.

b) Paul removed 2 beads, Joe removed 4 beads and Paul had to remove the last.

c) Paul removed 3 beads, Joe removed 3 beads and Paul had to remove the last, and so on.

So, Joe must have removed 3 beads at first to make 97 beads (1 more than multiple of 6) so that the last bead would be removed by Paul.

(A) 1

(B) 2

(C) 3

(D) 4

(E) 5



10. Alice, Betty, Cheryl, Daisy and Ella competed in a race. Each of them made two statements as shown below.

Alice: Daisy finished 2nd. Ella finished 3rd.

Betty: Alice finished 5th. Cheryl finished 1st.

Cheryl: Daisy finished 4th. Ella finished 2nd.

Daisy: Betty finished 1st. Cheryl finished 3rd.

Ella: Alice finished 2nd. Betty finished 1st.

Each girl was right about only 1 statement she has made.
Who finished 2nd in the race?

[Logical reasoning]

Alice and Cheryl both made two statements about Daisy and Ella.

If Alice was right about Daisy finishing 2nd, then Cheryl was right about Ella finishing 2nd.

This is not possible.

This means that Ella finished 3rd and Daisy finished 4th.

Since Ella finished 3rd, Daisy was not right about Cheryl finishing 3rd.

This means that Betty finished 1st.

If Betty finished 1st, Betty was not right about Cheryl finishing 1st.

This means that Alice finished 5th.

So, Cheryl finished 2nd.

They finished the race in this order from 1st to 5th.

Betty, Cheryl, Ella, Daisy, Alice

(A) Alice

(B) Betty

(C) Cheryl

(D) Daisy

(E) Ella



Section B

Questions 11 and 12 carry 6 marks each.

11. In the cyptarithm below, each letter represents a different digit.

$$\begin{array}{r}
 \\
 - \\
 \hline

 \end{array}$$

What 4-digit number does ABCD represent? [Cryptarithm]

Each letter represents a different digit.

So, letter A must be a digit 1 more than D.

Since A is 1 more than D, there is renaming in the tens and ones digits. Observe that since D is 1 less than A, C must be 9.

Since $8 - B = B$, $B = 4$.

Since there is renaming in the thousands and hundreds digits,

$A = 14 - A$. So, $A = 7$.

So, $D = 6$.

ABCD represents 7496.

$$\begin{array}{r}
 \\
 - \\
 \hline

 \end{array}$$

$$\begin{array}{r}
 \\
 - \\
 \hline

 \end{array}$$



12. Ali has between 70 and 100 cookies. He divides all the cookies equally into 3 jars and he has 1 cookie remaining.

He then divides all the cookies in one of the jars into 3 equal packets. 1 cookie remains in the jar.

He then divides all the cookies in one of the packets onto 3 equal plates. 1 cookie remains in the packet.

How many cookies does he have?

[Problem solving / Simultaneous concept]

All cookies \rightarrow 3 jars + 1 cookie

1 packet \rightarrow 3 plates + 1 cookie
3 packets \rightarrow 9 plates + 3 cookies

1 jar \rightarrow 3 packets + 1 cookie
1 jar \rightarrow 9 plates + 3 cookies + 1 cookie
1 jar \rightarrow 9 plates + 4 cookies
3 jars \rightarrow 27 plates + 12 cookies

All cookies \rightarrow 27 plates + 12 cookies + 1 cookie
All cookies \rightarrow 27 plates + 13 cookies

The number of cookies Ali has is 13 + a multiple of 27.

$$3 \times 27 = 81$$

$$13 + 81 = 94$$

He has 94 cookies.